

Standard Instruments for X-ray Diffraction and Scattering

Yuya Kubota, Taito Osaka, Tadashi Togashi, Shigeki Owada
SACLA



Pump-probe X-ray diffraction and scattering measurements are mainly used to investigate ultrafast phenomena in materials at SACLA. Several diffractometers are available depending on the measurement targets. The timing jitter between XFEL and optical laser has been reduced, which enables us to observe the photo-induced coherent phonon in bismuth without the arrival timing monitor.

Standard Setup for Pump-Probe X-ray Diffraction

4-Circle Diffractometer (Huber Co.)

<https://www.xhuber.com/en/>

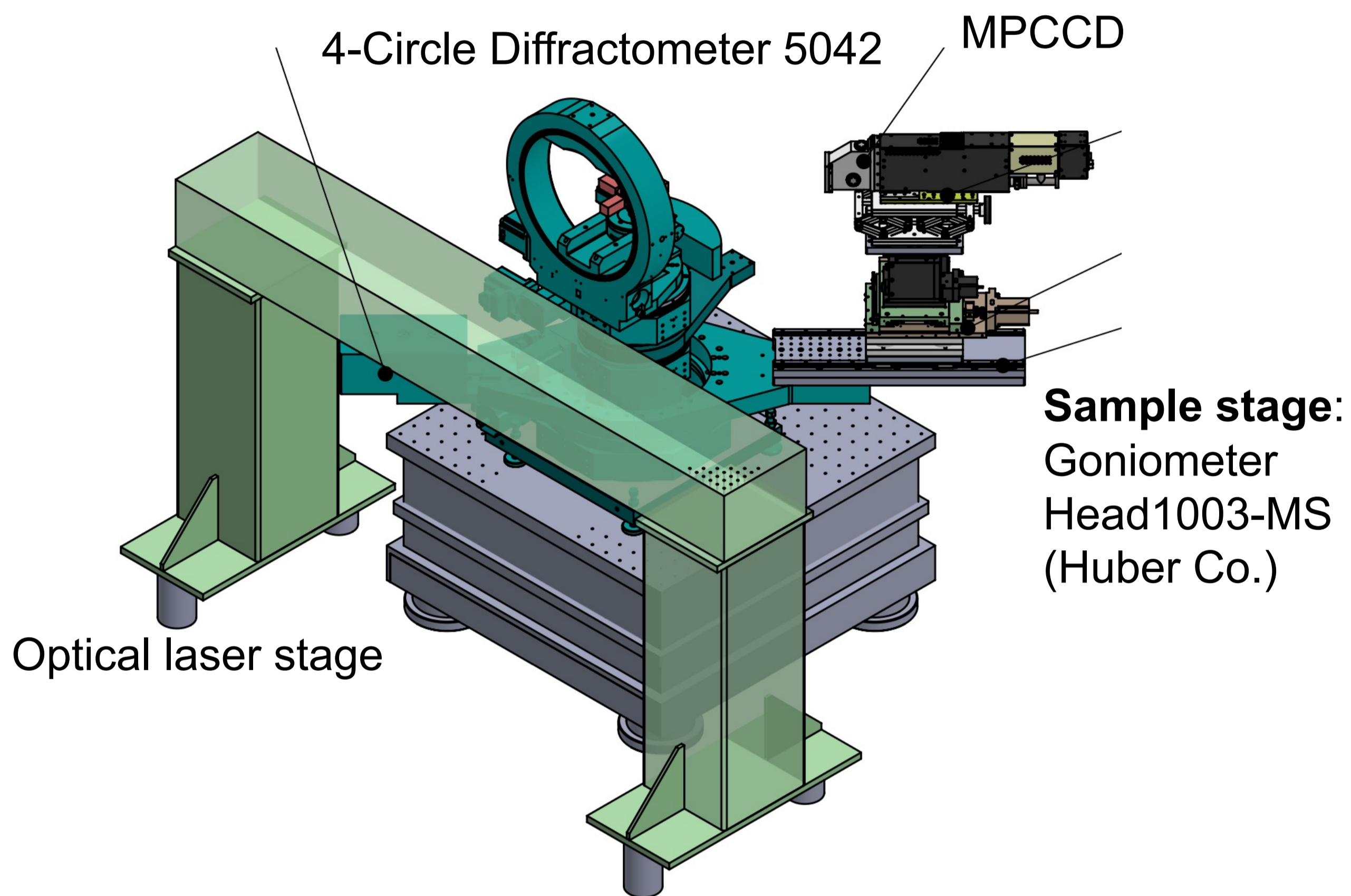

Optical Laser

T. Togashi *et al.*, Appl. Sci. **10**, 7934 (2020)

	Fundamental	Second Harmonic	Third Harmonic
Wavelength	800 nm	400 nm	267 nm
Pulse energy	~12 mJ	~0.5 mJ	~0.2 mJ
Pulse duration	~40 fs	~30 fs	~50 fs

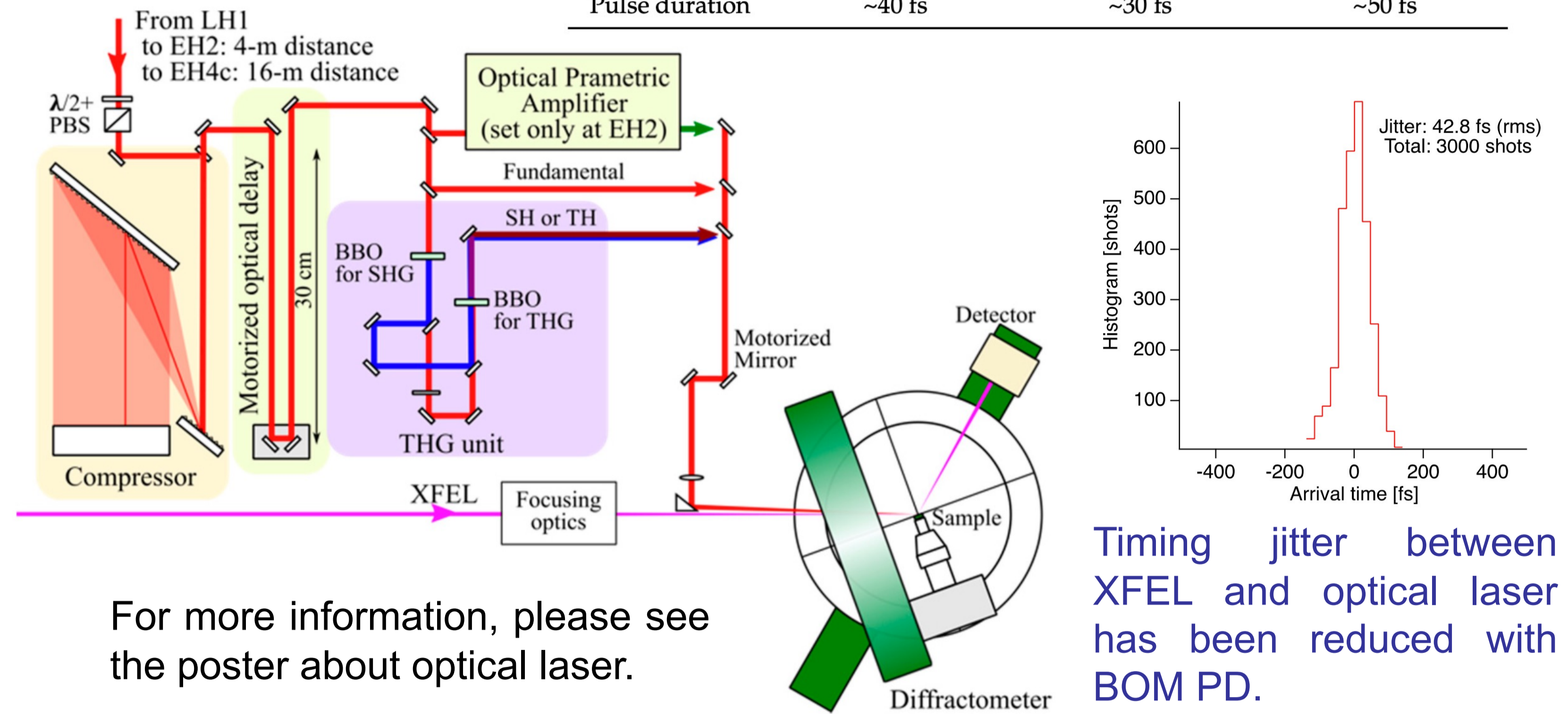

For more information, please see the poster about optical laser.

Timing jitter between XFEL and optical laser has been reduced with BOM PD.

Typical result

Photo-induced coherent phonon in Bi

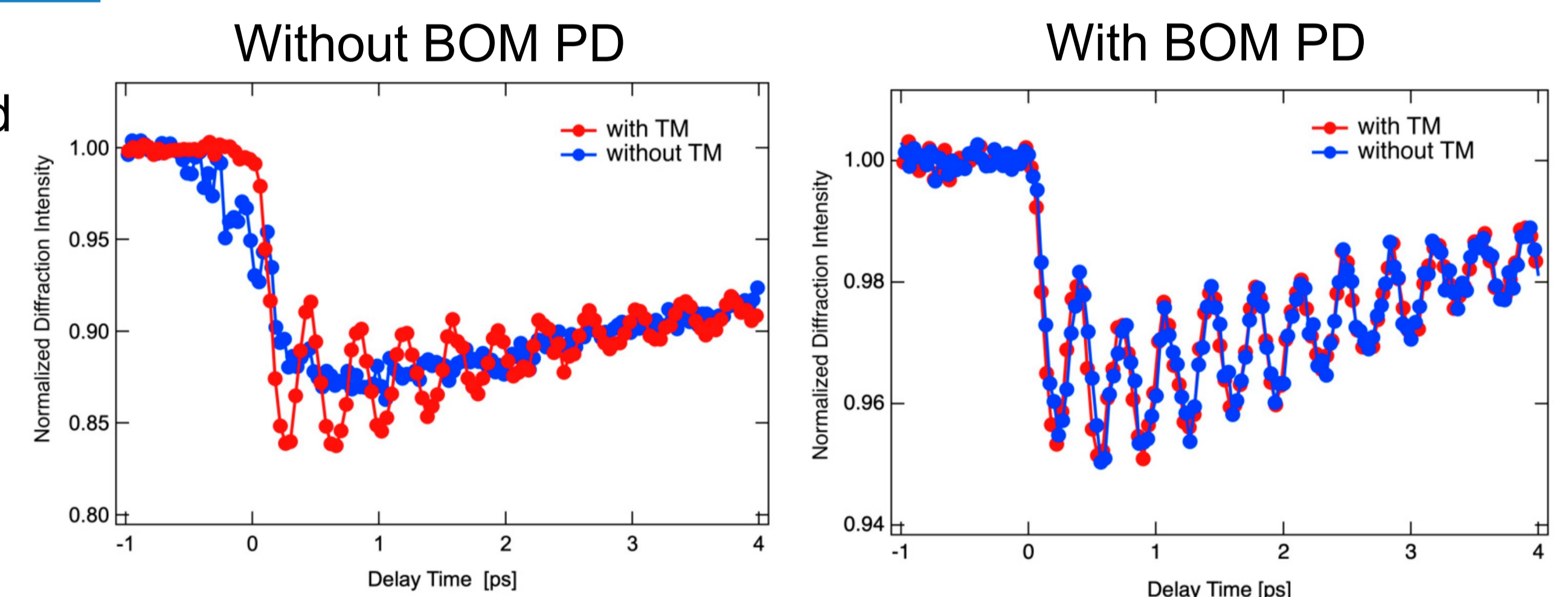

Options

- Cryostat (down to < 10 K)
- Cryostream (down to ~ 100 K)
- liquid N₂ (Oxford Cryosystems, <https://www.oxcryo.com/product/cryostream-800>)
- N₂ gas (Rigaku, <https://www.rigaku.com>)
- MIR~THz pump source
- spec software (<https://certif.com/content/spec/>)

Other Instruments

X-ray Diffuse Scattering

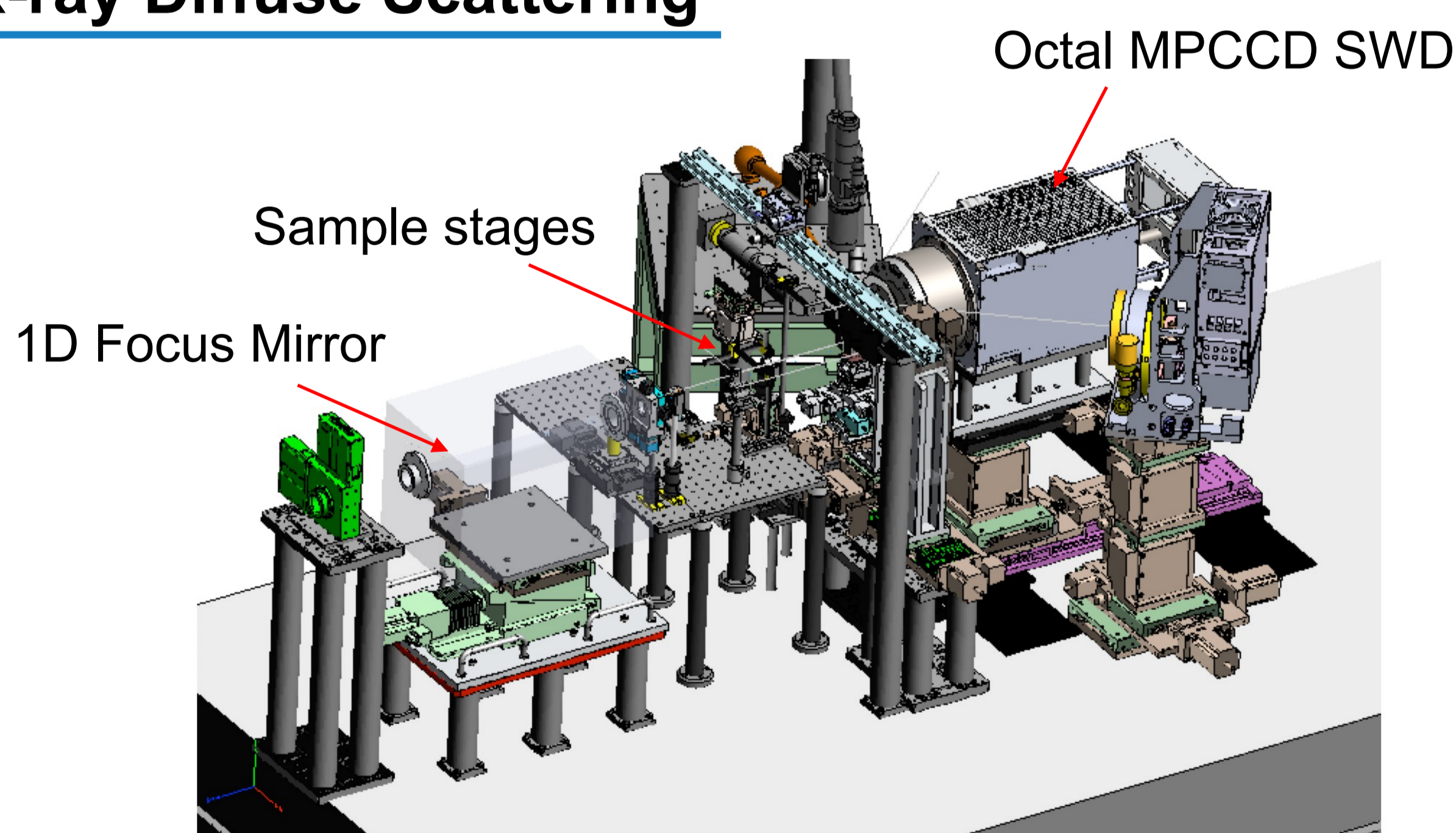

General-Purpose Diffractometer (KOHZU Co.)

<https://www.kohzuprecision.com/>

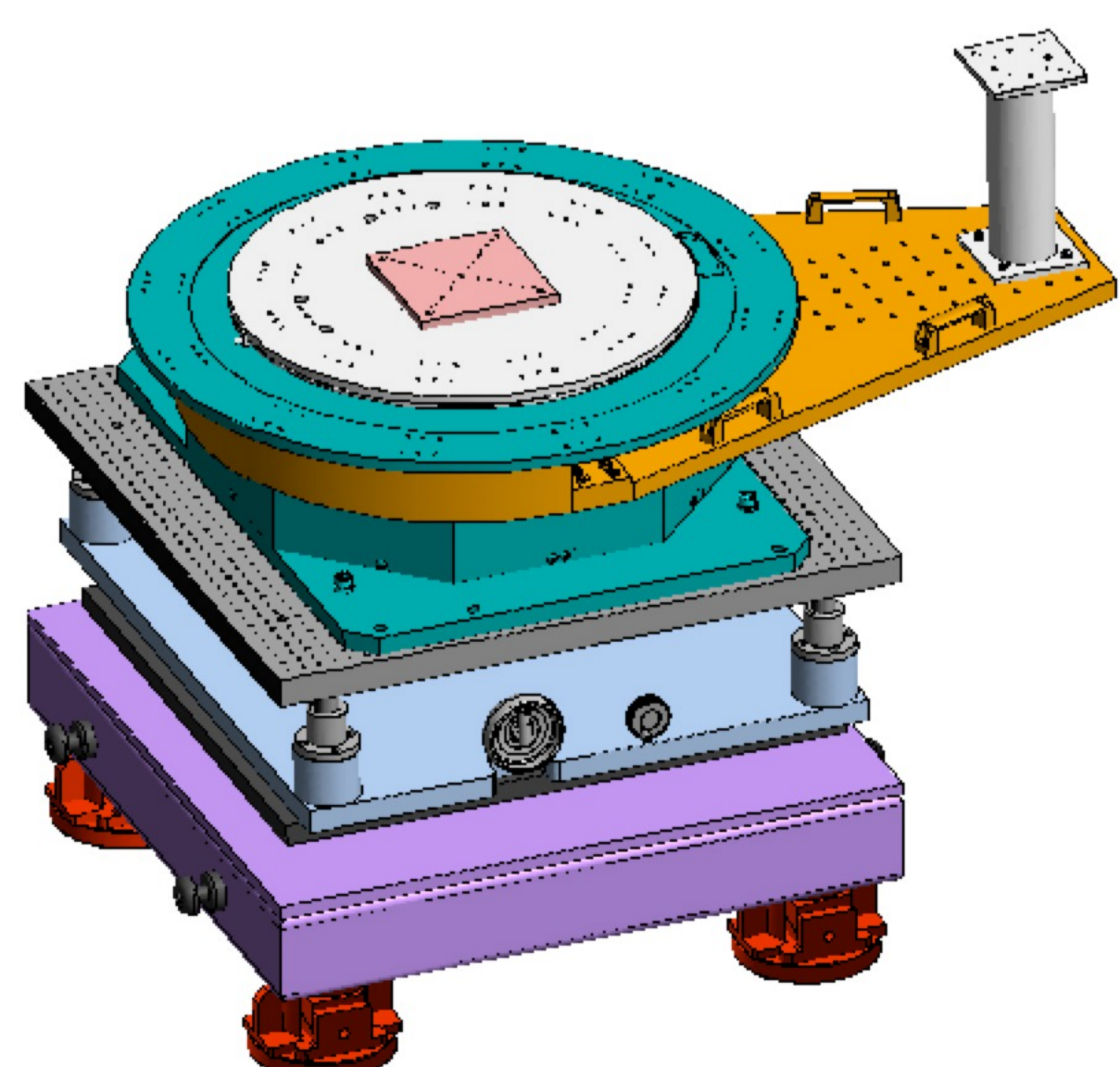

Theta
Size: ϕ 700 mm
Res.: 0.00004 deg/pulse
2Theta
Arm length: 1000 mm
Res.: 0.00004 deg/pulse

Diffractometer with Kappa Goniometer (Huber Co.)

<https://www.xhuber.com/en/>

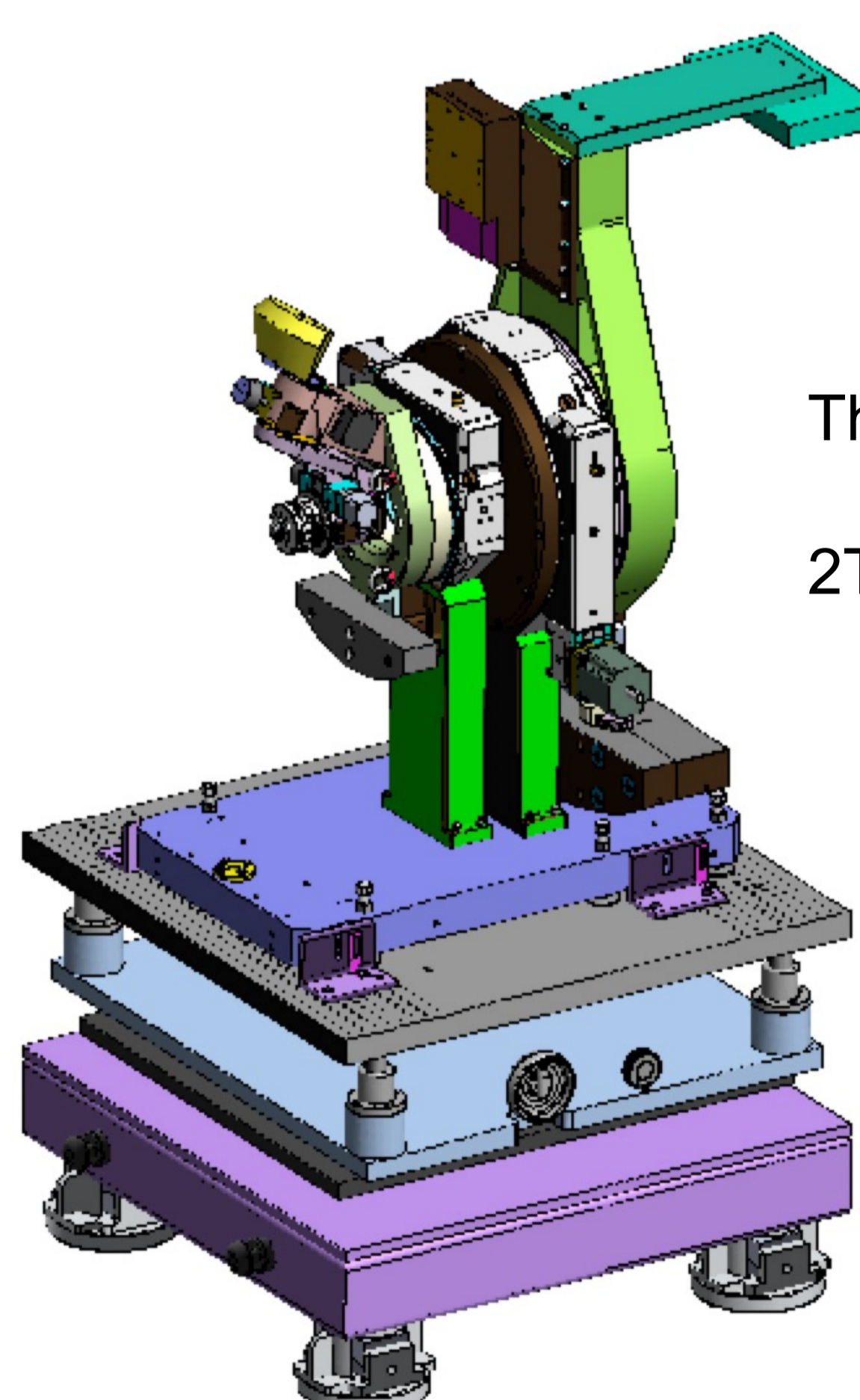

Kappa Goniometer 515.2
k stage
x, y stages
z stage
 ϕ stage

Theta Goniometer 420
0.0001 deg/pulse
2Theta Goniometer 440
0.0001 deg/pulse

- More freedom around the sample
- Vertical reflection geometry

Available from 2022B

Resonant Inelastic X-ray Scattering (RIXS)

RIXS system is under development at SACLA in the SACLA Basic Development Program.
For more information, please see Dr. M. Dean's talk on March 3.